

Choice PR2si 2 Channel Programmer w/ Service Interval Function



Benefits

The Choice PR2si is a two channel programmer with service interval functionality to ensure compliance with 'Gas Safety (Installation and Use) Regs 1998'. It is mandatory that all landlords carry out an annual gas safety check on gas appliances in their rented properties and this device is intended to act as a supplementary aid to enabling compliance.

The Choice PR2si allows the service interval to be set after completion of the boiler service and to activate after a period (i.e. 12 months when the gas safety check is due). If the warnings are ignored and the safety check becomes overdue the Choice PR2si can be set to fully or partially shut down the boiler.

Features

- 24 hour, 5/2 day and 7 day selectable
- 2 or 3 ON/OFF periods selectable
- 1,2 or 3 hour boost
- Advance to next programmed event
- Automatic Summer/Winter time change
- Holiday feature
- Program options - ON, OFF, All day or Auto
- Mains powered with battery backup
- Standard wall plate - simple plug in and replace

Service Interval Features

- Full or partial shutdown of the heating system once a service period is overdue
- Service period is set by installer using unique key code (0-400days)
- Visual warnings via the display and the display backlight are shown with 28 days & 7 days remaining and when overdue
- Full shutdown will prevent the boiler operating until the Choice PR1n is reset
- Partial shutdown allows the heating to operate for a variable 15 minutes every programmed hour to ensure some heat is still available

Applications

- For rented accommodation where access to carry out the statutory annual gas safety check is difficult
- Fully pumped central heating systems using mid-position valves, spring return valves or power open, power closed valves.
- Gravity hot water, pumped heating systems with or without motorised valves fitted into the domestic hot water primary circuit.

Technical Data

Power Supply:	230V AC, 50Hz
Operating Temperature:	0°C to 40°C
Switch Rating:	230V AC, 2(1)Amp per channel
Contact Type:	1B , Micro-Disconnection
Battery Type:	Lithium Cell CR2032
Enclosure Protection:	IP30
Plastics:	Thermoplastic, flame retardant
Insulation Class:	Double
Wiring:	For fixed wiring only
Backplate:	Industry standard
Dimensions:	140mm x 87mm x 37mm
Clock:	12 hour am/pm, 1 minute resolution, accuracy +/- 1.5 sec/day
BST/GMT time change:	Automatic
Program Cycle:	24hr, 5/2day or 7day selectable.
Program On/off per day:	2on/off, 3on/off selectable,
Program resolution:	10mins
Program Selection:	Auto, On all day, On constant, off
Program Override:	1, 2 or 3 hour, Advance
Heating System:	Pumped
Complies with :	EN60730-1, EN60730-2.7, EMC Directive 2004/108/EC, LVD Directive 2006/95/EC

Electrical Connections

Internal Wiring Diagram

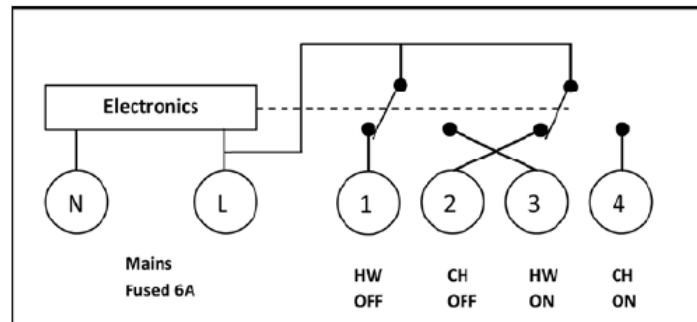

Contact Sangamo: 01475 745131

CUSTOMER CARE POLICY

As part of Sangamo's continuous improvement program, the Company operates a Customer Care Policy. This means that we welcome your comments and complaints, as it can only help us to improve our services to you, our customer.

SANGAMO

Sangamo Limited, Industrial Estate, Port Glasgow,
Renfrewshire PA14 5XG

Tel: 01475 745131 Fax: 01475 744567

Email : enquiries@sangamo.co.uk Web: www.sangamo.co.uk