



## PSB2

### Powersaver Boost Runback Timer

The latest ESP product manuals can be found on-line:



1

#### 1. Features:

The Powersaver Boost is a simple to use, multi application time switch. Although primarily used for the control of water heating, the PSB2 can also be used for a multitude of applications including the control of panel heaters, security lighting or combi boilers.

- Ideal for applications that need short term operating times
- 30 mins, 1 hour and 2 hour boost periods
- Fits directly onto a single gang pattress box
- Switches appliance off automatically after boost period

2

#### 2. Specifications:

- Contact Rating: 16A Resistive 240V a.c.  
2A LED Lighting 240V a.c.
- Supply: AC220~240V 50/60 Hz
- Terminals: suitable for max. 2.5 mm<sup>2</sup> flexible and 4.0 mm<sup>2</sup> fixed cabling
- Dimension: 86\*86\*35mm
- Operation Temperature: -10°C~40°C

Please Note : This is a Class 2 product



3

#### 3. Front View and Back View (Fig. 1 and Fig. 2)

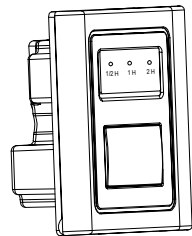

Fig.1 Front View

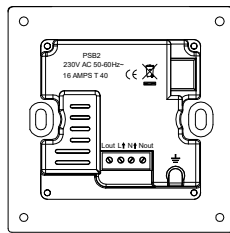

Fig.2 Back View

4

#### 4. Wiring Diagram

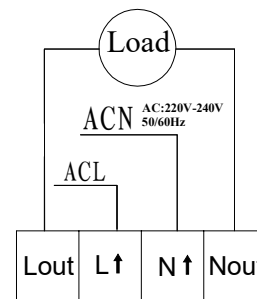

Fig.3 Wiring Diagram

5

#### 5. Installation Guide:

5.1 Flip open front plate from position A

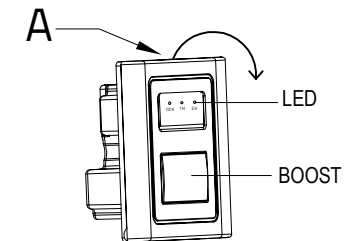

Fig.4

6

#### 5.2 Wire in accordance with the Wiring diagram and Terminal markings.

Input Voltage:

**AC220V-240V 50/60Hz**

Installation must be by a suitably qualified person in accordance with the latest IEE wiring Regulations.

Provision must be made in the fixed wiring for a means of disconnection from the supply having a contact separation of at least 3mm on all poles. This can be provided by the consumer unit.

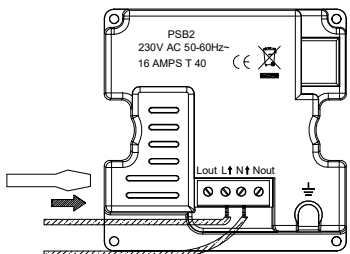

7

5.3 Fixing the mounting box on the wall and secure the unit to the mounting box with the 3.5mm screws provided.

a,b: Fixing Holes

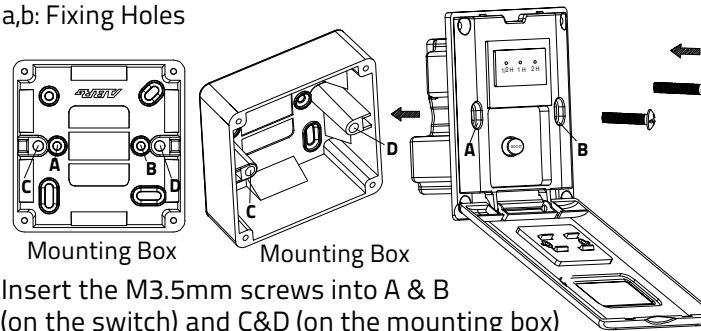

Mounting Box

Mounting Box

Insert the M3.5mm screws into A & B (on the switch) and C&D (on the mounting box) mounting holes.

Fig.6

8

#### 6. Operation Guide:

The Powersaver Boost offers 3 options for the on period duration using the BOOST button or the hidden BOOST button behind front plate.

**Press once = 30 mins**

**Press twice = 1 hour**

**Press three times = 2 hour**

**Press four times = Cancel function**

Duration can be extended or cancelled by successive presses.

9

7. When flip down the front panel, users can also set the boost timer with the hidden keypad as Fig. 7.

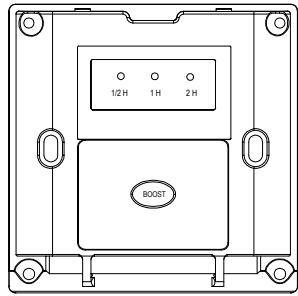

Hidden Keypad

Fig.7

10

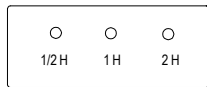

3 user-selectable boost periods

7.1 Press Boost button once: 1/2 H LED light illuminates. The loads turn on, and will turn off automatically 1/2H later;

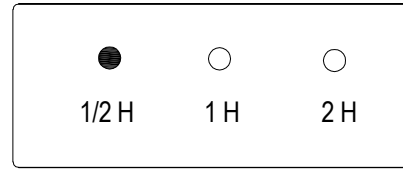

Fig.8

11

7.2 Press Boost button twice: 1H LED light illuminates. The loads turn on, and will turn off automatically 1H later;

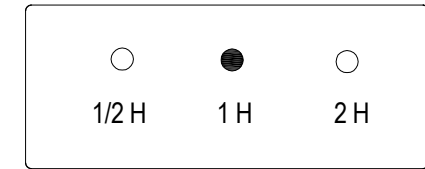

Fig.9

12

7.3 Press Boost button three times: 2H LED light illuminates. The loads turn on, and will turn off automatically 2H later;

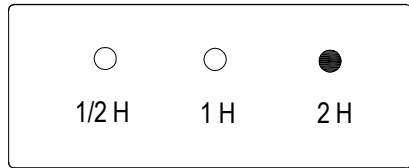

Fig.10

13

7.4 Press Boost button four times: the Boost function is canceled, the loads and all the LED lights will turn off.

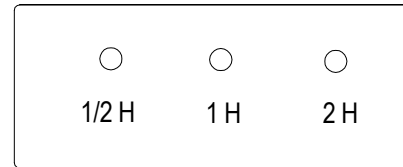
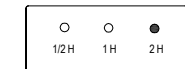

Fig.11

14

8. While the Boost timer is active the indicator light will change to show the maximum remaining time; e.g. 2 Hours selected.



2 Hours selected



After 1 Hour

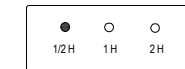

After further 1/2 Hour

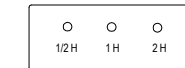

After 2 Hours total

Fig.12

15

9. Extend Boost:

While delay-off period, press the 'BOOST' button can extend the Boost time and the corresponding indicator light will turn on. For example, if '1H' selected, when the loads is on, press 'BOOST' button again, the Boost time will be extended to 2H, and the 2H LED light will illuminate. Press 'BOOST' button again, boost is canceled and the loads will turn off.

16



Elite Security Products  
Unit 7, Target Park,  
Shawbank Rd, Lakeside,  
Redditch, B98 8YN

Telephone: 01527 51 51 50  
Fax: 01527 51 51 43 Email:  
info@espuk.com Web:  
www.espuk.com

E&OE - Errors and omissions excepted. K19

17

Date Issued	Issue No	Description
24/09/2019	A30-PSB2-01-1	Initial Issue

18