

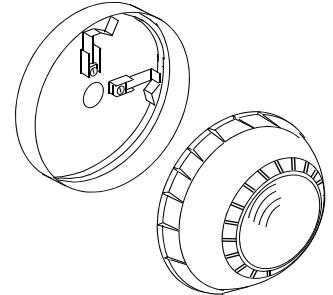

General Description

The MAGDUO Sounder unit allows for audible indication when the system enters an alarm condition. This device is compatible with the MAGDUO range of Fire Alarm equipment and comprises a 2-wire zone-powered sounder. This device may be installed on the same zone as the FlexiPoint detector/sounder and associated MAGDUO devices.



Before Installation

The Sounder must be installed in compliance with the control panel installation manual. The installation must also meet the requirements of any local authority. For maximum performance the sounder should be installed in compliance to BS5839 Pt1 : 2017.

Spacing

It is recommended spacing sounders in accordance with BS5839 Pt1. For more specific information regarding sounder spacing, placement and special applications please refer to BS5839 Pt1 : 2017.

Device Installation

Fix the base in a suitable position using the two screw holes provided, remembering to allow enough space for the correct termination of the appropriate fire resistant cable.

Once all testing has been carried out on the cabling and 'continuity & integrity' has been proven, the device may be assembled. To insert the Sounder unit, gently offer it into the base, rotating the device until it drops in and clicks into its locked position.

Please remember that all high voltage testing must be carried out before the installation of the sounder front unit.

Connections

All wiring must be installed in compliance with the recommendations laid out by BS5839 Pt1 : 2017 as well as any special recommendations documented in the control panel installation manual. The cabling used should be of a 2-core 1.5mm² screened, fire resistant type (e.g. MICC or FP200 equivalent), and is to be wired in the form of a screened 2-core radial circuit (with no spurs) from the control panel, terminating at the last ("End of Line") device.

Remember that the device at the end of the line must have its EOL signal activated using the relevant EOL switch. Do not use a resistor or capacitor (or another manufacturer's End of Line device) as the end of line, as this may prevent correct operation of the zone.

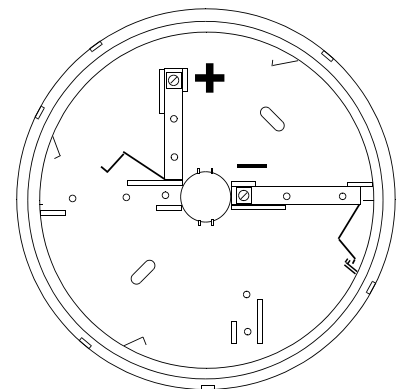

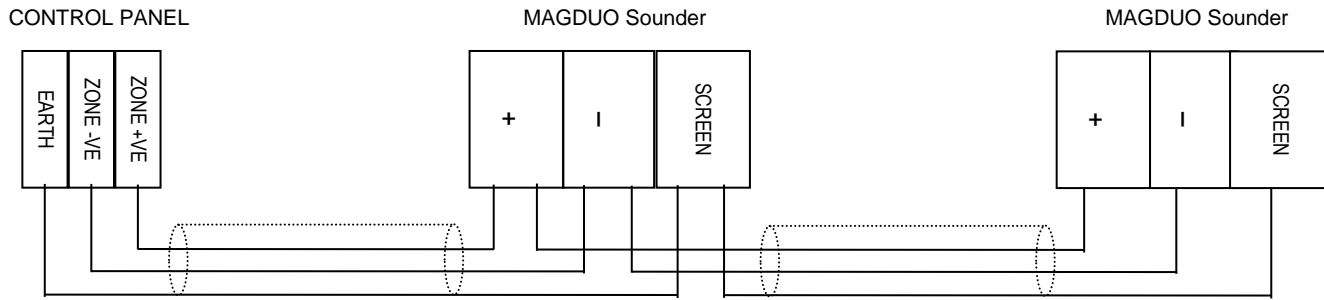

The MAGDUO Sounder can be mixed on the same zone as other types of MAGDUO devices. The above diagram shows how to make the zone positive, zone negative and screen connections between the control panel and MAGDUO Sounders. Refer to the instruction leaflets supplied with other MAGDUO devices for their equivalent wiring/terminal labelling details.

The screens of the incoming and outgoing zone cables must be connected together using a suitable terminal block (not included). Please note that these cable screens should NOT be connected to the building earth at the sounders. The cable screen is connected to earth at the panel end only, via the zone “SCRN” terminal (or EARTH terminal on the MAGDUO panel). It is important to maintain the screen/earth continuity in order to protect against data corruption from interference.

DIL Switch Settings

The last device on the circuit must have the EOL signal enabled (switch number 1 in the ‘ON’ position). This may be altered when the device is removed from the base.

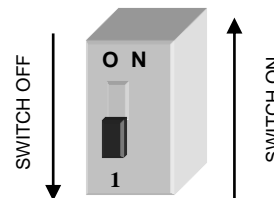

		DIL SWITCH SETTINGS
		1
End of line	Enabled	ON
	Disabled	OFF

Volume Control

The sounder is supplied from the factory with the volume set to maximum and should normally be left set this way.

If you do need to adjust this, the volume can be controlled with the rotary control on the PCB, using a small screwdriver. The approximate minimum and maximum volume positions are marked. The rotary control itself is marked with a circle on either side of the selection pointer as shown.

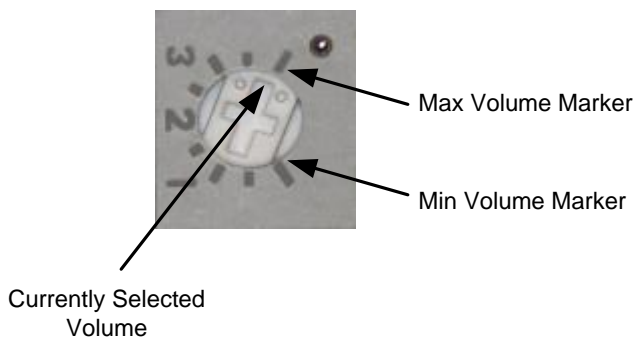

NOTE: that the minimum volume which can be set is no sound. Care should therefore be taken when setting up a sounder for very low volume. In any case, it is important to ensure that sound volumes meet all regulatory requirements for your installation.

Technical Data

Dimensions	Diameter105mm
	Depth72mm
Operating Temperature-10°C to +50°C.
Voltage Ranges	DC Output from Mains Powered Panel ...25.5 to 35V DC
	DC Output from Battery Powered Panel .20 to 26V DC
Operating Current (Typical)	Quiescent92 uA
	End of line ON if applicable561 uA
	<i>(in addition to Quiescent)</i>
	Alarm Sounding – Maximum Volume10 mA
Volume Level	Alarm Sounding – Maximum Volume.....90+ dB (A) @ 1m anechoic (Dual Tone)
Loading Units	
	Max Device Loading Units per zone 160 DLU
	Sounder36.0 DLU
FlammabilityUL94-V2
IP RatingIP 21C
Part Codes	RedMAGDUOSR
	WhiteMAGDUOSW

Maintenance

There are no user serviceable parts inside. Wipe the outside of the sounder with a damp (not wet) cloth.

Technical Support

Due to the complexity and inherent importance of a life risk type system, training on this equipment is essential, and commissioning should only be carried out by competent persons.

ESP's policy is one of continual improvement and the right to change a specification at any time without notice is reserved. Whilst every care has been taken to ensure that the contents of this document are correct at time of publication, ESP shall be under no liability whatsoever in respect of such contents. E&OE.

www.espu.com

 0832	
Elite Security Products LTD Unit 7 Target Park, Shawbank Road, Lakeside, Redditch, B98 8YN England 11 DoP-MAGDUOSR-01, DoP-MAGDUOSWS-01	
EN54-3: 2001 +A1: 2002 +A2: 2006 Sounder Technical Data See: 26-1649	
Intended for use in the fire detection and fire alarm Systems in and around buildings	
Essential characteristics	Performance
Nominal activation conditions/Sensitivity, Response delay (response time) and performance under fire conditions	Pass
Operational reliability	Pass
Durability of operational reliability and response delay, Temperature resistance	Pass
Durability of operational reliability, Vibration resistance	Pass
Durability of operational reliability, Humidity resistance	Pass
Durability of operational reliability, Corrosion resistance	Pass
Durability of operational reliability, Electrical stability	Pass
Performance under fire conditions	Pass
Durability of operational reliability, Resistance to ingress	Pass